

## SPECIFICATIONS

Dimension	Metric	British
Max. Working Height <b>A</b>	35.00m	114' 10"
Max. Platform Height <b>B</b>	33.00m	108' 3"
Overall Length <b>C</b>	7.15m	23' 5"
Overall Width <b>D</b>	1.40m	4' 7"
Overall Height(Rails Up) <b>E</b>	4.23m	13' 10"
Overall Height(Rails Down) <b>F</b>	3.36m	11'
Platform Size(Length ×Width )	6.50m×1.20m	21' 4"×3' 11"
Platform Extension Size <b>G</b>	1.90m	6' 3"
Ground Clearance(Stowed/Raised)	0.19m/0.02m	7"/1"
Wheelbase <b>H</b>	5.43m	17' 10"
Turning Radius(Inside/Outside)	3.20m/3.80m	10' 6"/12' 6"
Tyres	28×14×22	28×14×22

Performance		
S.W.L	750kg	1653lb
S.W.L on Extension	750kg	1653lb
Max. Occupants (Indoor/Outdoor)	2/2	2/2
Gradeability	25%	25%
Travel Speed(Stowed)	≥1.5km/h	≥0.93mph
Travel Speed(Raised)	≥0.1km/h	≥0.06mph
Max. Working Slope(X/Y)	1°/0°	1°/0°
Up/Down Speed	180/180sec	180/180sec

Weight		
Overall Weight	28400kg	62611lb

Power		
Hydraulic Tank	280L	74gal
Lithium Battery	80V/620Ah	80V/620Ah
Charger	80V/80A	80V/80A
Driving Motor	4×56VAC/6kW	4×56VAC/6kW
Lifting Motor	53VAC/28kW	53VAC/28kW

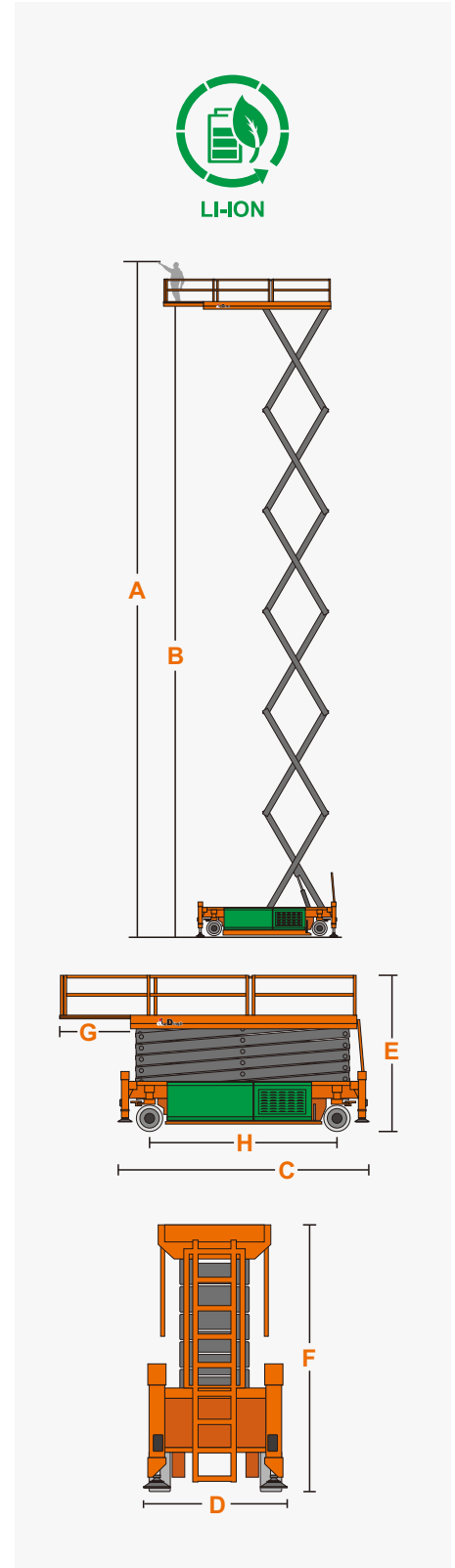

## FEATURES

### Standard Items

- Proportional Joystick Controls
- Self-Locking Gates
- Four-Wheel Drive
- Four-Wheel Steering
- Drivable At Full Height
- Automatic Braking System
- Self-Weight Lowering System
- Tubing Explosion-Proof System
- Onboard Fault Diagnostic System
- Tilt Alarm
- Motion Alarm
- Horn
- Hour Meter
- Flashing LED Beacon
- Foldable Guard Rails
- Drive Enable
- Manual Brake Release
- Lanyard Attachment Point
- Tie-Down And Lifting Points
- Automatic Leveling Hydraulic Outriggers
- Emergency Pump
- Emergency Stop Button
- Platform Load Sense System
- Visual Level
- Outrigger Mats



### ZHEJIANG DINGLI MACHINERY CO., LTD.

Address: No.188 Qihang Road,Deqing,Zhejiang P.R.C 313219

Telephone: +86(572)8681688

E-Mail: [export@cndingli.com](mailto:export@cndingli.com)

[Https://en.cndingli.com](https://en.cndingli.com)

Due to continuous technology updates, technical parameters are subject to change without notice. This picture book is for reference only, the actual product shall prevail. The copyright is owned by zhejiang dingli, any content may not be copied for any purpose without written permission.

2024-09

