

SPECIFICATIONS

Dimension	Metric	British
Max. Working Height A	18.00m	59' 1"
Max. Platform Height B	16.00m	52' 6"
Max. Drive Height	16.00m	52' 6"
Overall Length C	4.88m	16'
Overall Width D	2.33m	7' 8"
Overall Height(Rails Up) E	3.23m	10' 7"
Overall Height(Rails Down) F	2.47m	8' 1"
Platform Size(Length ×Width)	4.88m×1.83m	16'×6'
Platform Extension Size G / H	1.43m/1.13m	4' 8"/3' 8"
Ground Clearance(Stowed/Raised)	0.30m	1'
Wheelbase I	2.86m	9' 5"
Turning Radius(Inside/Outside)	2.70m/5.50m	8' 10"/18'
Tyres	315/55/D20	315/55/D20

Performance		
S.W.L	680kg	1499lb
S.W.L on Extension	227kg	500lb
Max. Occupants(Indoor/Outdoor)	4/4	4/4
Gradeability	40%	40%
Travel Speed(Stowed)	≥6.0km/h	≥3.73mph
Travel Speed(Raised)(<11m/≥11m)	≥1.0km/h ≥0.6km/h	≥0.62mph ≥0.37mph
Max. Working Slope(<11m/≥11m)	2°/3° 1.5°/3°	2°/3° 1.5°/3°
Up/Down Speed	78/74sec	78/74sec

Weight		
Overall Weight	8840kg	19489lb

Power		
Diesel Engine	Kubota D1105/18.2kW	Kubota D1105/18.2kW
Diesel Tank	80L	21gal
Hydraulic Tank	120L	31gal
Lithium battery	80VDC/67.5Ah	80VDC/67.5Ah
Motor	80VDC/10kW	80VDC/10kW

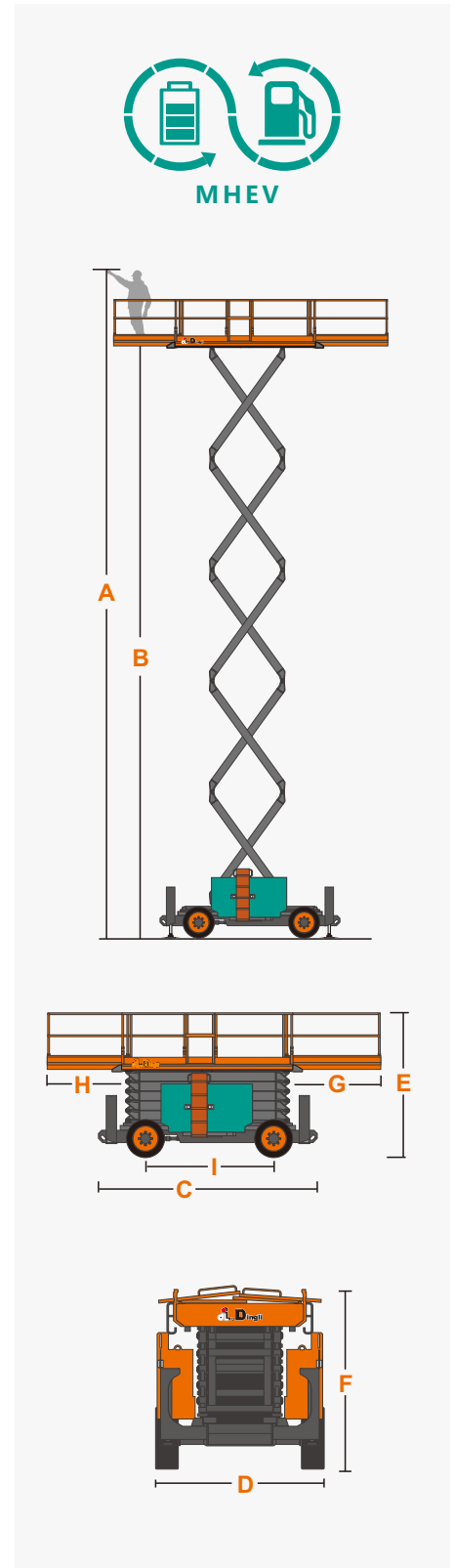

FEATURES

Standard Items

- Drivable At Full Height
- Proportional Joystick Controls
- Self-lock Gate On Platform
- Dual Slide-Out Platform Extension Deck
- Four-Wheel Drive
- Two-Wheel Steering
- Drive axle
- Automatic Brake System
- Self-Weight Lowering System
- Cylinder Holding Valve
- Onboard Diagnostic System
- Tilt Alarm
- All Motion Alarm
- Horn
- Hour Meter
- Hydraulic Oil Cooling System
- Flashing LED Beacon
- Foldable Guard Rails
- Drive Enable
- Manual Brake Release
- Lanyard Attachment Point
- Tie-Down And Lifting Points
- Automatic Leveling Hydraulic Outriggers
- Anti-Restart Engine Protection
- Emergency Pump
- Emergency Stop Button
- Platform Load Sense System
- Oscillating Axle Chassis

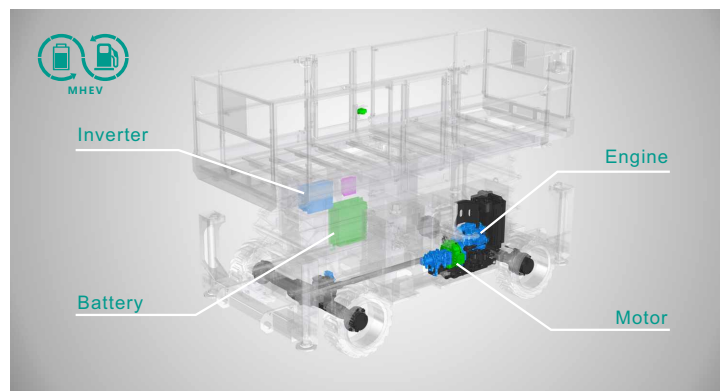

Mild Hybrid

ZHEJIANG DINGLI MACHINERY CO., LTD.

Address: No.188 Qihang Road,Deqing,Zhejiang P.R.C 313219

Telephone: +86(572)8681688

E-Mail: export@cndingli.com

[Https://en.cndingli.com](https://en.cndingli.com)

Due to continuous technology updates, technical parameters are subject to change without notice. This picture book is for reference only, the actual product shall prevail. The copyright is owned by zhejiang dingli, any content may not be copied for any purpose without written permission.

2024-12

