

## SPECIFICATIONS

Dimension	Metric	British
Max. Working Height <b>A</b>	18.00m	59' 1"
Max. Platform Height <b>B</b>	16.00m	52' 6"
Max. Drive Height	16.00m	52' 6"
Overall Length <b>C</b>	4.88m	16'
Overall Width <b>D</b>	2.33m	7' 8"
Overall Height(Rails Up) <b>E</b>	3.23m	10' 7"
Overall Height(Rails Down) <b>F</b>	2.47m	8' 1"
Platform Size(Length ×Width )	4.88m×1.83m	16'×6'
Platform Extension Size <b>G / H</b>	1.43m/1.13m	4' 8"/3' 8"
Ground Clearance(Stowed/Raised)	0.30m	1'
Wheelbase <b>I</b>	2.86m	9' 5"
Turning Radius(Inside/Outside)	2.70m/5.50m	8' 10"/18'
Tyres	315/55/D20	315/55/D20

Performance		
S.W.L	680kg	1499lb
S.W.L on Extension	227kg	500lb
Max. Occupants(Indoor/Outdoor)	4/4	4/4
Gradeability	40%	40%
Travel Speed(Stowed)	≥6.0km/h	≥3.73mph
Travel Speed(Raised)(<11m/≥11m)	≥1.0km/h ≥0.6km/h	≥0.62mph ≥0.38mph
Max. Working Slope(<11m/≥11m)	2°/3° 1.5°/3°	2°/3° 1.5°/3°
Up/Down Speed	78/74sec	78/74sec

Weight		
Overall Weight	8980kg	19798lb

Power		
Range Extended Engine	Kubota Z482/9.8kW	Kubota Z482/9.8kW
Diesel Tank	110L	29gal
Hydraulic Tank	80L	21gal
Lithium Battery	48V/350Ah	48V/350Ah
Charger	48V/60A	48V/60A
Driving Motor	32VAC/9kW	32VAC/9kW
Lifting Motor	32VAC/15kW	32VAC/15kW

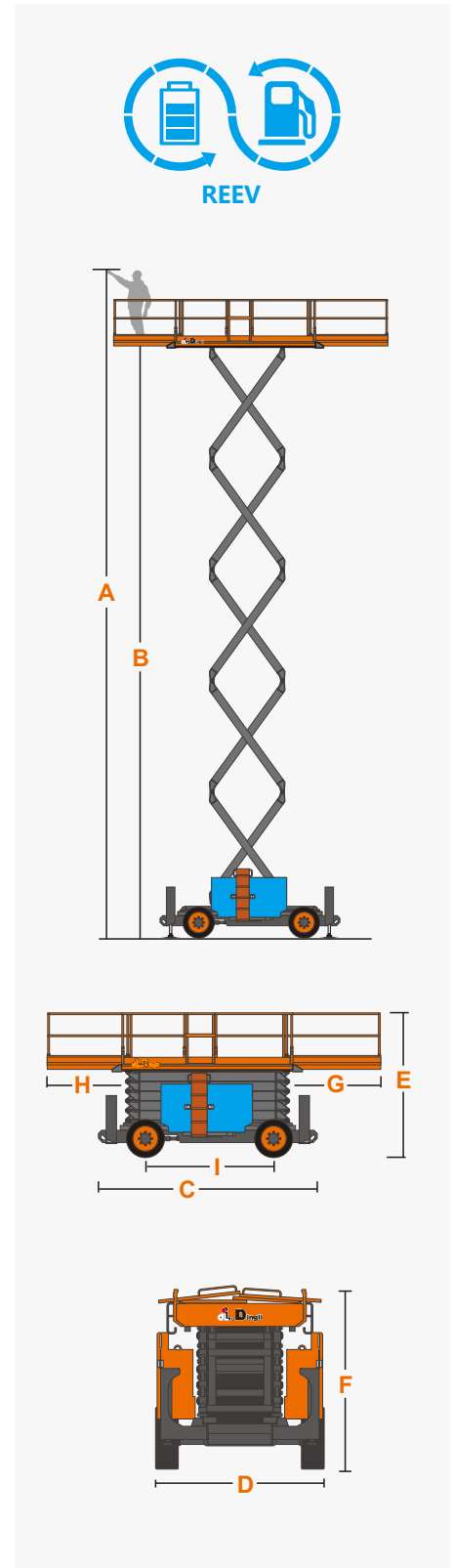

## FEATURES

### Standard Items

- Drivable At Full Height
- Proportional Joystick Controls
- Self-lock Gate On Platform
- Dual Slide-Out Platform Extension Deck
- Four-Wheel Drive
- Two-Wheel Steering
- Drive axle
- Automatic Brake System
- Self-Weight Lowering System
- Cylinder Holding Valve
- Onboard Diagnostic System
- Tilt Alarm
- All Motion Alarm
- Horn
- Hour Meter
- Flashing LED Beacon
- Foldable Guard Rails
- Drive Enable
- Manual Brake Release
- Lanyard Attachment Point
- Tie-Down And Lifting Points
- Automatic Leveling Hydraulic Outriggers
- Anti-Restart Engine Protection
- Emergency Pump
- Emergency Stop Button
- Platform Load Sense System
- Oscillating Axle Chassis

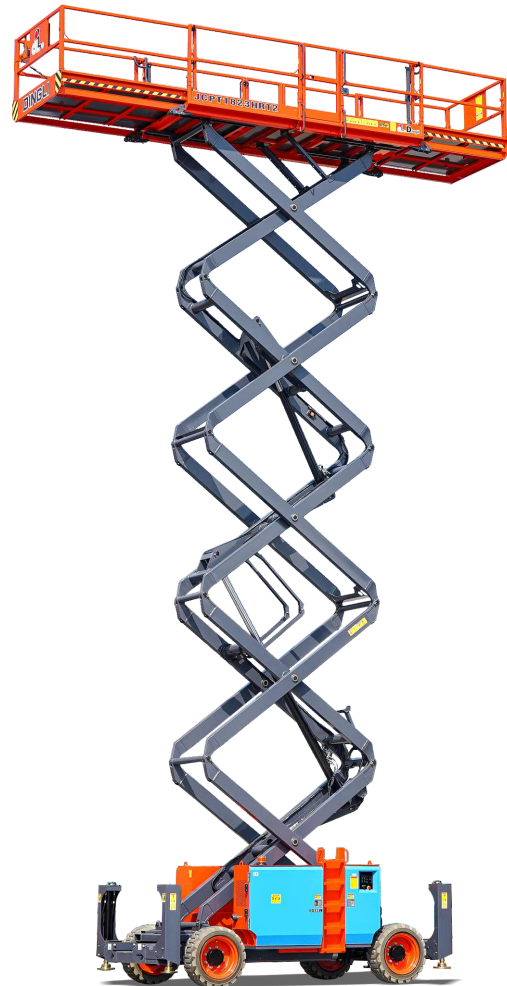

### ZHEJIANG DINGLI MACHINERY CO., LTD.

Address: No.188 Qihang Road,Deqing,Zhejiang P.R.C 313219

Telephone: +86(572)8681688

E-Mail: [export@cndingli.com](mailto:export@cndingli.com)

[Https://en.cndingli.com](https://en.cndingli.com)

Due to continuous technology updates, technical parameters are subject to change without notice. This picture book is for reference only, the actual product shall prevail. The copyright is owned by zhejiang dingli, any content may not be copied for any purpose without written permission.

2024-12

