

### SPECIFICATIONS

Size	Metric	British
Max. Working Height	20.23m	66ft 4in
Max. Platform Height	18.23m	60ft
Max. Operating Range(+0.6m)	13.36m	44ft
Max. Platform Range	12.76m	41ft 10in
Flatbed Transport Dimensions (L×W×H)	7.63m×2.44m×2.68m	25ft×8ft×8ft 9in
Standard Container Transport	All Applicable	All Applicable
Platform Size(Length×Width)	1.83m×0.79m	6ft×2ft 7in
Turntable Tailswing	1.24m	4ft 1in
Ground Clearance <b>A</b>	0.31m	1ft
Wheelbase <b>B</b>	2.40m	7ft 10in
Turning Radius(Inside/Outside)	3m/4.73m	9ft 10in/15ft 6in
Tyres	315/55D20	315/55D20

Performance		
S.W.L	320kg	705lb
Max. Occupants	2	2
Gradeability	40%	40%
Travel Speed(Stowed)	6.0km/h	3.7mph
Travel Speed(Raised)	1.1km/h	0.7mph
Max. Working Slope	X-5°/Y-5°	X-5°/Y-5°
Turret Rotation	360°Continuous	360°Continuous
Platform Rotation	180°	180°
Jib Movement	132°	132°

Weight		
Overall Weight	8600kg	18959lb

Power		
Diesel Engine	Kubota Z482/9.8kW	Kubota Z482/9.8kW
Battery	48V/300Ah	48V/300Ah
Charger	48VDC/60A	48VDC/60A
Driving Motor	34AC/9kW	34AC/9kW
Lifting Motor	34VAC/13kW	34VAC/13kW
Diesel Tank	90L	23gal
Hydraulic Tank	145L	38gal

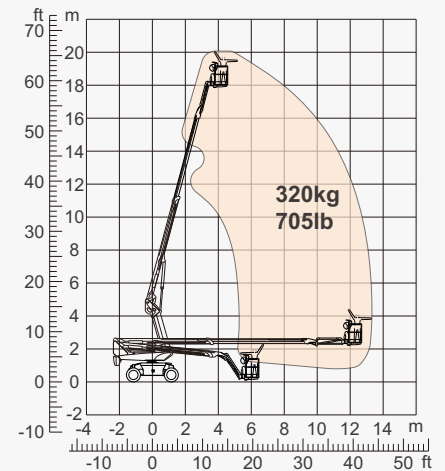
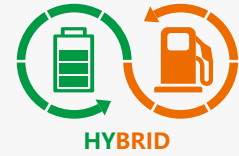

Range Of Motion

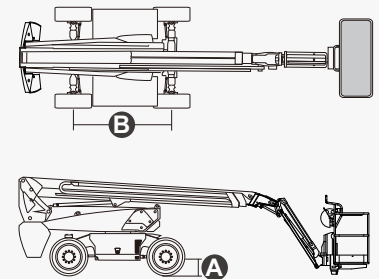

## FEATURES

### Standard Items

- 1.50m (4ft 11in) Jib
- Front Oscillating Axle
- Two-Wheel Steering
- Four-Wheel Drive
- Self-Leveling Platform
- 180° Left And Right Swing Platform
- Proportional Joystick Controls
- Thumb Rocker Steer
- Drive Enable
- Ac Power Cord To Platform
- Tilt Alarm
- Descent Alarm
- Flash
- Horn
- Hour Meter
- Integral Integrated Special Drive Axle For Construction Machinery
- 360° Continuous Turntable Rotation
- Positive Traction Four Wheel Drive
- Platform Load Sense System
- Fault Diagnosis System
- Operator Anti-crushing Protection System
- Harsh Environment Kits
- 12V DC Auxiliary Power
- Battery 300Ah/48V
- Driving Motor 9kW 4834rpm
- Lifting Motor 13kW 1855rpm



Telescopic Boom-BT



Working Height-20m



Jib



Hybrid-H



Rough Terrain-RT

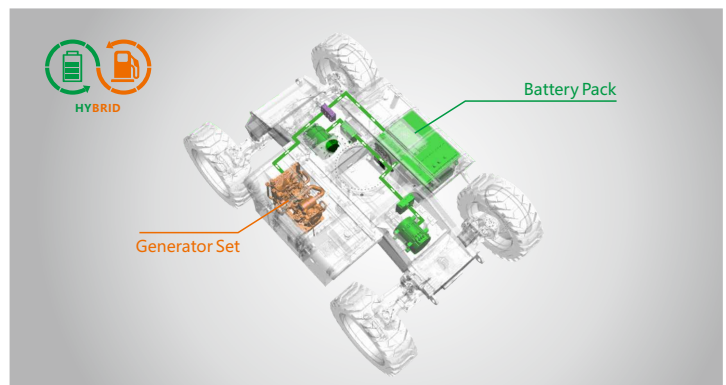

Hybrid-Super Long Endurance Of 30 Days

### ZHEJIANG DINGLI MACHINERY CO., LTD.

Address: No.188 Qihang Road,Deqing,Zhejiang P.R.C 313219

Telephone: +86(572)8681688

E-Mail: export@cndingli.com

Https://en.cndingli.com

Due to continuous technology updates, technical parameters are subject to change without notice. This picture book is for reference only, the actual product shall prevail. The copyright is owned by zhejiang dingli, any content may not be copied for any purpose without written permission.

2023-07

